

BLACK SWAMP BEEMER

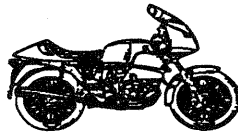

ZEIT • GEIST

BMW Riders of Toledo

Vol. I • No. 6 • Sept. 1, 1993

Meeting Change!

SPECIAL ANNOUNCEMENT

The September meeting day has been moved to the 3rd Thursday of the month. That will be on September 16, 1993 at 7:00pm (not at 7:30pm which is the usual time slot). This meeting will be held at Freindship Park in Perrysburg, located at the corner of E. Boundry and S.R. 795.

Breakfast at the Toussaint

Sunday, August 22, we had our second club breakfast ride of the '93' riding season. This breakfast was another successful club activity totally in keeping with the trend we are experiencing this year.

I arrived about 8:20am on a brisk yet sunny Sunday morning and parked the PD at the side of the lot. I stepped out of the aerostitch riding suit and decided to wait outside with the bike until others had arrived.

I didn't wait long before Pres. Wade rolled in on his R65, sounding vaguely like a Harley. We stood around the bikes talking and waiting for about 10min. then we went inside to claim a large table or booth for the anticipated crowd.

By the time we ordered coffee, Jim Merzke turned into the lot on his R80RT and parked

next to our mounts. By the time he was seated and had ordered another beemer was pulling into the drive, This was Ron and Nancy Berry on their K100RT. When they took a seat at the table we decided to order breakfast.

The next rider to arrive was David Williams aboard his '73' R75/5, replete with toaster tank and short frame. David is a fellow Onizer, he and I rode to the RA National in Vermont at the end of June. When David came in the waitress informed him that the last to arrive paid the check. He didn't have long to worry about that as the next rider wheeled into the lot.

Gayle Snively rode in next on her Yamaha SECA, with the Rapid Transit faring. She didn't get caught up in the joke about the check as another motorcycle arrived as she was settling in.

Riding on a Yamaha Venture Royal was Bob and Marilyn Klear. They were on their way to Cedar Point.

The best suprise of the day was yet to come as Jim Guinan, the man we rarely ever see (except at the breakfast), seated on his R65 and four other bikes one of them two up, rolled into view. The folks riding with Jim were, Steve Guinan riding a 400 Honda which he had purchased in Colorado and rode back to this area and he hadn't ridden

before. Also Guy Stout aboard his Honda Shadow, Justin Ward on his Honda 750CBK and Eric Rajski with Christine Felthous mounted upon an R100RT.

These are all very nice people and I hope they consider socializing with the club.

(Continued on PG.2)

OFFICERS:

President

Wade Kemp

535 W. Gypsy Lane #272
Bowling Green, OH 43402
(419) 354-0243

V. Pres./Road Captain.

Owen Marshall
3599 W. Samaria Rd.
Temperance, MI 48144
(313) 856-1743

Secretary

Frank Crawford
7852 County Rd. C
Delta, OH 43515
hm.(419) 822-5315
wk.(419) 247-7107

Treasurer

Leo Peiffer
1923 County Rd. 14
Gibsonburg, OH 43431
(419) 637-7778

RIDE SAFE

OSHKOSH B'GOSH

The BMW MOA 21st National Rally in Oshkosh Wisconsin is history. But the memories of a great time and ride linger on.

As I sit and look at the many photo's taken at the rally and the ride there, I remember the feelings of freindship amongst the membership and our freinds as we rode or rallied together. We have begun the slow and long up-hill trek to an active and vital club.

We are gaining membership at every turn.

Toussaint Breakfast

(Continued from PG.1)

This was an excellent event with great participation. After breakfast we stood around the bikes talking and getting aquainted. The group thinned out as riders left for their afternoon activities.

This is really working!

So make a note and be sure to remind yourself to attend the third RoT ride for breakfast at the Village Inn Restaurant, 4984 S Main St. in Sylvania at the corner of Brint Rd. 8:00am till 11:00am. If yopu need explicit directions, just call me at 247-7107 or 822-5315.

Please come won't ya?

Frank

*Saturday
Sept. 1993*

*Saturday
Sept. 1993*

BMW R 1100

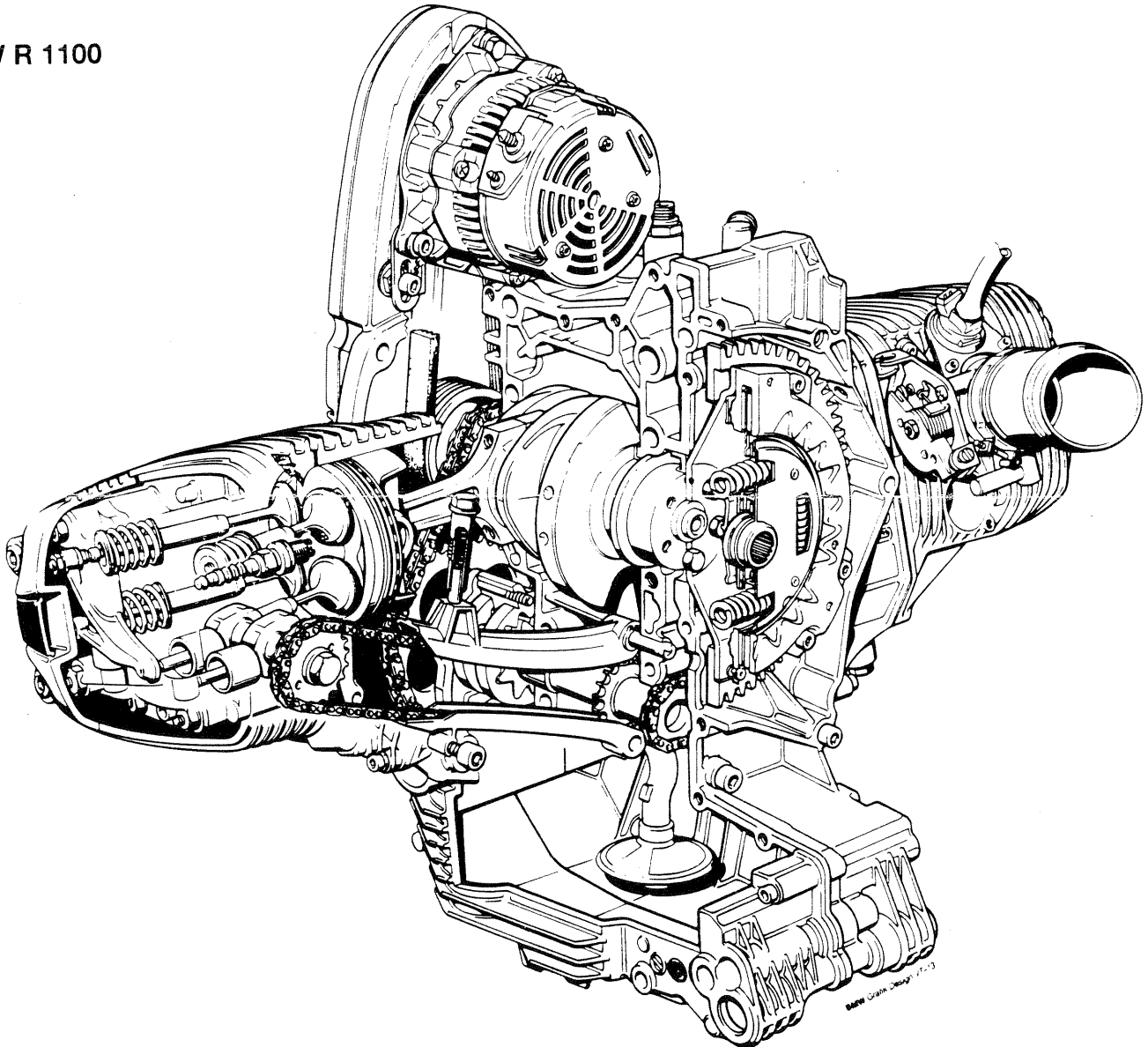

MONTHLY MINUTES

The August meeting of the BMW Riders of Toledo was held on 8/10/1993 at Phillis and Leo Peiffers near Gibsonburg.

Called to order: At 7:35pm.

Roll Call: Conducted by the usual sign-in and accepted as written. Those in attendance were:

Frank Crawford (Sec.)	Leo Peiffer (Treas.)
Kelly Thrush (Guest)	Phyllis Peiffer
Carfol Smith	Kathy Peiffer (Guest)
Don Smith	Jim Merzke
Jim Taylor (Prospective member)	Lois Merzke
Jim Brower	Ron Berry (Host)
James Brower (Guest)	Wade Kemp (Pres.)
Owen Marshall (V.P. & Road Captain)	Bob Peck
Lee Conkey (Prospective member)	Elijah Peck (Guest)
Dale K. Foster	Ryan McGuire (Guest)
Gayle Snively	

Minutes: The June minutes were read by Frank. There were no additions or corrections. Jim Merzke made the motion to accept and Jim Brower seconded, motion passed unopposed.

Financial Report: The financial report from Leo states that we had two months go by and the bank charged us \$5.00 service charge per month so we have \$1132.04 in the bank. Leo also stated that he still had not got to the bank to deposit the \$20.00 he has from dues which he reported at the last meeting. Frank motioned to accept & Owen 2nd. Passed.

Officers Reports:

President: Thanks to Phillis and Leo for their hospitality and glad to see all of you.

Secretary: I stated that we've been having a great year for membership participation in club events from all appearances. Two great national rallies. The club was well represented in Oshkosh. We had very good attendance at our last breakfast and I suspect we will have good one at our next breakfast.

Vice-President: I'd like to introduce Jim Taylor, I've known him for a few years and he went to the national with usa and had a real good time. I hope he considers joining the club.

Old Business: Dale brought up the matter of the BMW maintenance videos which we approved purchase of at the June mtg. Dale felt that we were sticking our neck out ordering all three without knowing the quality of them. There was some discussion and most of us agreed with Dale. So we decided to order one tape and determine if we feel it's worth keeping and then purchasing the others. Frank made a motion that we buy the Boxer 10K service video. Jim Merzke seconded. Motion passed unopposed.

The matter of the Adopt A Highway program was discussed and it was determined that we are presently unable to field a clean-up crew, so we tabled the issue until next year.

New Business: A breakfast at the Toussaint on August 22 was discussed. This event will be held from 8:00am until 10:00 or 10:30.AM.

Dale brought up the issue of offering incentive for members to attend the meetings, i.e., a drawing for a prize with a nominal value of \$10.00. Dale also talked about picnic and camp-out type get togethers for the club members. Discussion was had and we decided not to offer incentive as we get good turn out from the members as it is. Frank mentioned that some members are not able to attend Tuesday mtg's. so we agreed to try another day of the week next month.

September Meeting: The September Meeting will be at Freindship Park in Perrysburg at the intersection of E. Boudry and State Route 795. The meeting will be held on Thursday September 16 at 7:00pm.

The meeting closed at 8:19pm.

Ride FREE!

ATTENTION!

• MEETING •

• ANNOUNCEMENT •

The September meeting day of the BMW Riders of Toledo has been changed from the usual second Tuesday to the third Thursday, September 16 and the time is moved up to 7:00pm

The location for the September meeting will be, Freindship Park at the corner of S.R.795 and East Boundry in Perrysburg.

This change is part of an effort to bring members to the meetings who are not able to attend on the usual meeting night.

So please come if you can and bring a freind also.